

# News 2019

complements / beds



**Alf DaFre®**



Nel segno della continuità, Alf DaFrè accoglie i suoi ospiti in uno spazio dall'atmosfera contemporanea per raccontare con semplicità il suo modo di interpretare la casa. La qualità dei prodotti è naturalmente l'elemento chiave, unita al design essenziale e curato nei dettagli che caratterizza ogni sistema e ogni elemento di arredo Alf DaFrè. Gordon Guillaumier, Meneghello Paoelli Associati, Enrico Cesana e il team dello studio tecnico Alf DaFrè, sono gli autori di prodotti nuovi e del restyling di prodotti esistenti per quanto riguarda sia i sistemi, sia gli arredi.

As a sign of continuity, Alf DaFrè welcomes its guests into a contemporary space to clearly illustrate the way in which it interprets the home. The quality of the products is naturally the key element, together with the well-finished, simple design that characterises each collection and piece of furniture by Alf DaFrè. Gordon Guillaumier, Meneghello Paoelli Associates, Enrico Cesana and the Alf DaFrè technical team are the creative behind the new products and existing product restyles both for the compositions and furniture.

“

**KENDO**, è una famiglia di madie dal design brillante, razionale e tecnicamente raffinato. Kendo vuole suggerire con il suo design l'essenza della cultura giapponese in merito alle arti marziali e in particolare rispetto al culto della spada. Il concetto del “taglio” identifica chiaramente il focus della collezione, ossia una netta lacerazione di 30° sul frontale, dalla quale scaturiscono due ante “disassate” che sono cuore ed anima della collezione.

**KENDO** is a product family of sideboards that stands out for its brilliant, rational and technically sophisticated design. The Kendo design sets out to reflect the essence of Japanese culture in the ambit of the martial arts, with a particular reference to the sword cult. The “cut” concept clearly identifies the focus of the collection, in the form of a sharp 30° front cleft, producing two offset doors that are the heart and soul of the collection.

”

Meneghello Paoletti Associati

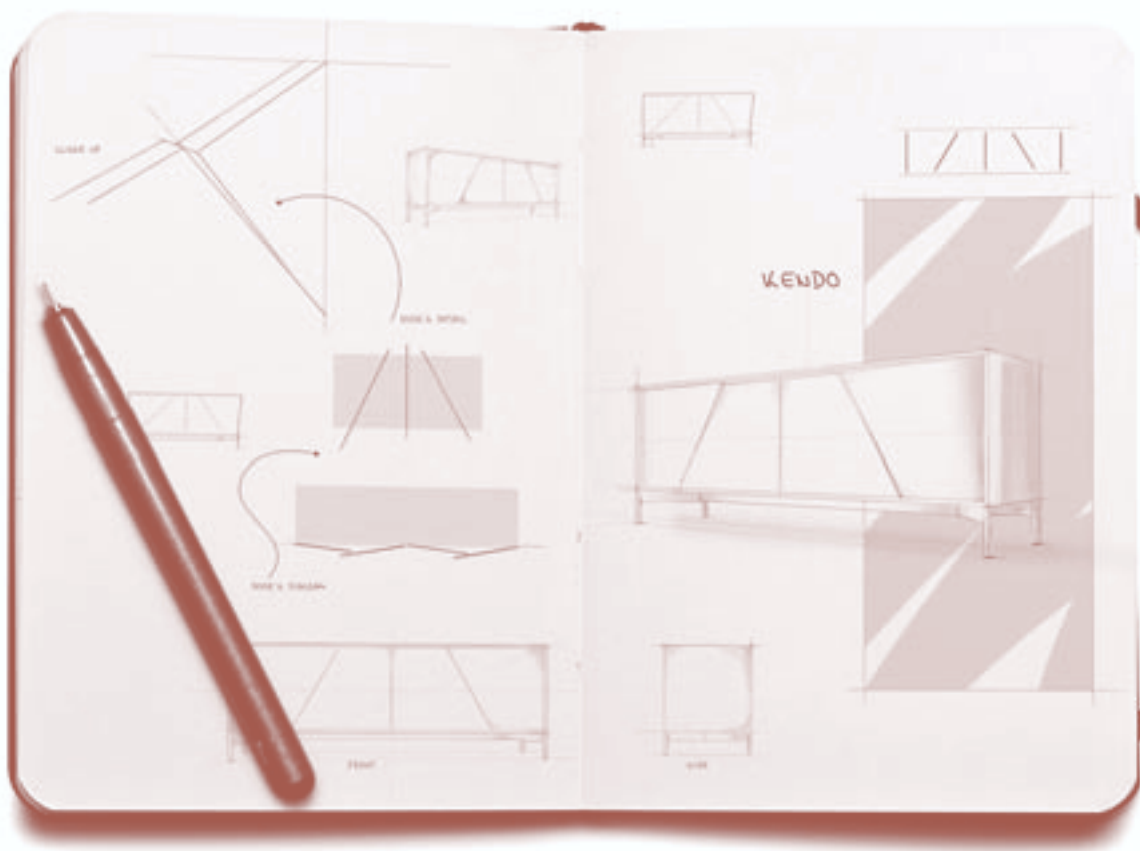



## MENEGHELLO PAOLELLI ASSOCIATI

Product designers, consulenti strategici per il prodotto industriale, Sandro Meneghello e Marco Paoelli costituiscono Meneghello Paoelli Associati. Laureati nel 2004 al Politecnico di Milano, sotto la guida di Roberto Palomba e Paolo Rizzatto, dopo diverse esperienze internazionali - dalla Central Saint Martins di Londra e la Norwegian University of S&T di Trondheim, alla Köln Kisd University e EDF R&D di Parigi - fondano il loro studio a Milano. Dal 2005 si affiancano ad aziende italiane ed internazionali con il fine di creare valore aggiunto attraverso il design di prodotto. Hanno ricevuto numerosi riconoscimenti internazionali, tra cui cinque Red Dot Design Award, cinque Design Plus, due Good Design Award, un ADI Design Index, due menzioni speciali per il German Design Award e sei menzioni allo Young&Design.

As product designers and strategic consultants for industrial products, Sandro Meneghello and Marco Paoelli make up Meneghello Paoelli Associates. They graduated in 2004 from the Polytechnic university in Milan, under the guidance of Roberto Palomba and Paolo Rizzatto and, after various international experiences – from the Central Saint Martins University in London and the Norwegian University of Science & Technology in Trondheim, to the Köln International School of Design and EDF R&D in Paris – they founded their studio in Milan. Since 2005 they have been working alongside Italian and international companies with the aim of creating added value through product design. They have received numerous international awards, including five Red Dot Design Awards, five Design Plus awards, two Good Design Awards, one ADI Design Index award, two special mentions for the German Design Award and six Young&Design mentions.

### KENDO / p. 40-43



“ Per il letto NEYŌ ho pensato a delle forme morbide, consone al concetto dell'intimità sviluppandole attorno al tema della sospensione e leggerezza, assieme a quello materico per accentuare la dimensione tattile e visiva.

For the NEYŌ bed I thought of soft shapes, in keeping with the concept of intimacy, developing them around the theme of suspension, lightness and texture to accentuate the tactile and visual dimension.

Gordon Guillaumier





## **GORDON GUILLAUMIER**

Gordon Guillaumier nasce nel 1966. Studia a Malta, in Svizzera, in Inghilterra e in Italia. Si diploma in industrial design presso lo IED di Milano (1988-1991) ottenendo successivamente un master in industrial design presso la Domus Academy, Milano (1992).

Nel 1993 dopo l'apprendistato presso Baleri Associati, collabora con Rodolfo Dordoni, disegnando i suoi primi pezzi. Nel 2002 apre il proprio studio, occupandosi di design consulting, product and interior design.

Ha collaborato con Azzurra Ceramiche, Bosa, Ceramiche Piemme, Desalto, DeSede, Driade, FontanaArte, Foscarini, Gebruder Thonet, Frag, Matteo Grassi, Minotti, Moroso, Oluce, Pamar, Paola C, Roda, Tacchini.

Tra i suoi vari riconoscimenti ricevuti sono: Interzum 2011 Award, Wallpaper Design Award 2014, Compasso d'Oro 2016.

Le sue opere di interior design e architettura, pubblicate dalle più prestigiose riviste e libri del settore, si concentrano principalmente su progetti residenziali privati. Ha insegnato presso la facoltà di design industriale del Politecnico di Milano e professore in visita all'Abadir Design Academy di Catania. La sua collaborazione per Alf DaFrè per cui firma numerosi progetti inizia nel 2017.

Gordon Guillaumier was born in 1966. He studied in Malta, Switzerland, England and Italy. He graduated from the IED in Milan in industrial design

(1988-1991) and then obtained a master's degree in industrial design from the Domus Academy, Milan (1992). In 1993, after his apprenticeship at Baleri Associati, he collaborated with Rodolfo Dordoni, designing his first pieces. In 2002, he opened his own studio where he offers product and interior design services and design consulting. He has collaborated with Azzurra Ceramiche, Bosa, Ceramiche Piemme, Desalto, DeSede, Driade, FontanaArte, Foscarini, Gebruder Thonet, Frag, Matteo Grassi, Minotti, Moroso, Oluce, Pamar, Paola C, Roda and Tacchini.

He has received various awards including the Interzum 2011 Award, the Wallpaper Design Award 2014, and the Compasso d'Oro 2016.

His interior design and architectural works, published in some of the most prestigious magazines and books in the field, mainly focus on private residential projects. He has taught at the Faculty of Industrial Design at Milan's Polytechnic university and is a visiting professor at the Abadir Design Academy in Catania. He began collaborating with Alf DaFrè in 2017 and has designed numerous projects.

**RAKU** / p. 14, 17, 23-29, 43, 46-55, 81, 91-92, 97,103

**NEYŌ** / p. 70-79, 82-83

“ RAKU è una collezione di sedute imbottite nata come estensione di Neyō. ho voluto dare un'anima unica a questa collezione che vive bene assieme o come singoli pezzi, sia per la zona notte sia per spazi giorno della casa e aree contract.

RAKU is a collection of upholstered chairs, created as an extension of Neyō. I wanted to give a unique feel to this collection that works well together or as single pieces, both in the bedroom, as well as in the living room and in larger business spaces.

Gordon Guillaumier

”

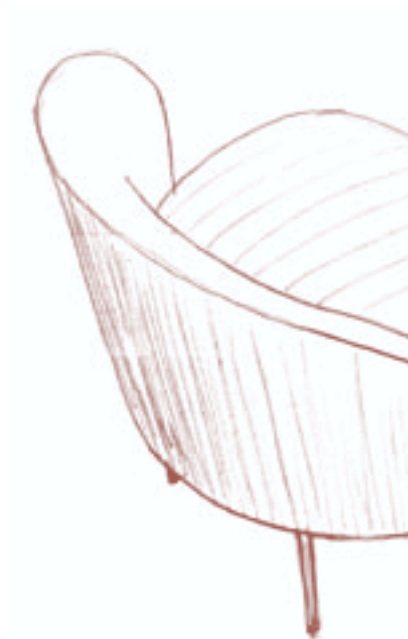







“ CALIFORNIA è un prodotto “storico” dell’azienda, pensato per integrarsi con i sistemi giorno aziendali; oggi è ripensato dal punto di vista funzionale per adattarsi alle nuove esigenze abitative. Nuove tipologie di seduta, nuove profondità, nuove funzioni permettono a California una contemporaneità senza tempo ed una capacità di adattarsi ad ogni spazio domestico.

CALIFORNIA is one of the company’s historic products, designed to integrate with its living room collections; today it has been reworked in terms of its function to adapt to new living requirements. New types of seat, new depths and new functions ensure California remains current and adaptable to any domestic space.

”

Enrico Cesana

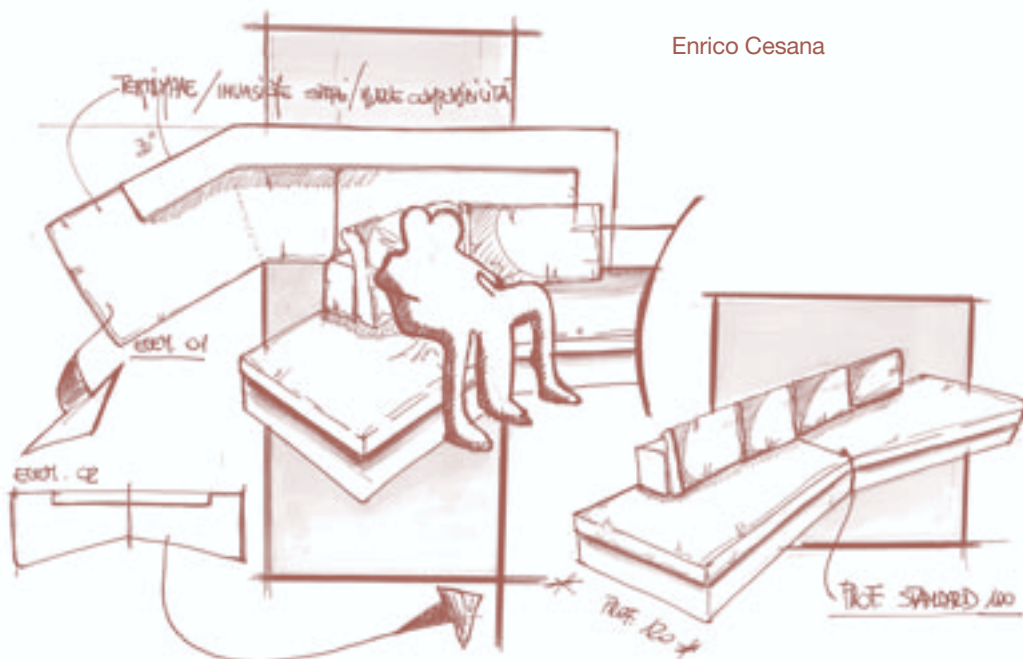



## ENRICO CESANA

Enrico Cesana nasce nel 1970. Ha frequentato la facoltà di architettura al Politecnico di Milano dove si è laureato nel 1997. Dal 1998 al 2004 due esperienze professionali felici lo portano ad occuparsi di industrial ed interior design e ad approfondire metodi ed approcci progettuali diversi. Nel 2005 apre il proprio studio a Lissone (MB), occupandosi di industrial design, architettura e comunicazione; firma più di 100 prodotti per importanti realtà italiane – tra cui SpHaus, Ivano Redaelli, Gruppo Industriale Busnelli, Acam, Cinova, Orizzonti, Olivieri, Alivar, My Home collection, Dorelan e Alf DaFrè – e progetta i concept store per Corner Optique by Randazzo, Next People by Aureli, Optissimo Gruppo Randazzo, Samsonite e Cleaf Spa. Progettista versatile e prolifico, ama descriversi come un “designer al servizio delle aziende”.

Enrico Cesana was born in 1970. He attended the Faculty of Architecture at Milan's Polytechnic university, where he graduated in 1997. Between 1998 and 2004, two enjoyable professional experiences led him to focus on industrial and interior design and to investigate various design methods and approaches. In 2005, he opened his own industrial design, architecture and communication studio in Lissone (MB); he has designed more than 100 products for leading Italian concerns, including SpHaus, Ivano Redaelli, Gruppo Industriale Busnelli, Acam, Cinova, Orizzonti, Olivieri, Alivar, My Home collection, Dorelan and Alf DaFrè, and has designed the concept stores for Corner Optique by Randazzo, Next People by Aureli, Optissimo Gruppo Randazzo, Samsonite and Cleaf Spa. He is a versatile and prolific designer, who loves to describe himself as a “designer catering to the needs of companies”.

**NEVADA** / p. 32-39  
**CALIFORNIA** / p. 14-21  
**COPENAGHEN** / p. 86-93

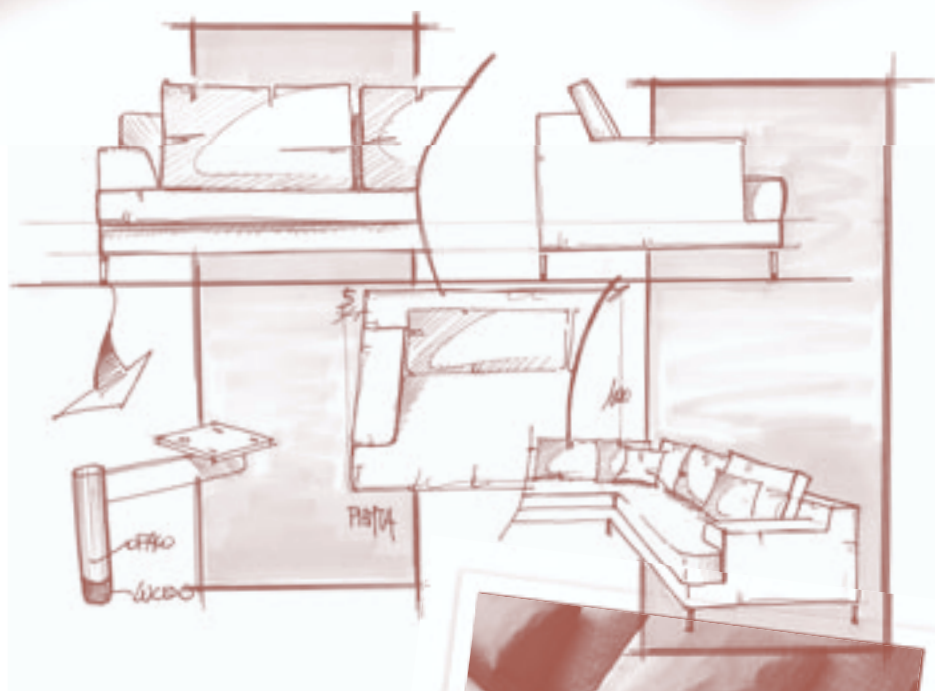

“

**NEVADA è pensato per fare da trait d'union tra la tradizione e la contemporaneità.**

**Le forme si fanno meno rigorose e più morbide ed accoglienti, l'immagine generale leggera è accentuata dal disegno essenziale ed aereo dei piedini in metallo. Molti elementi compositivi permettono di configurare la soluzione adatta per ogni abitazione.**

**NEVADA is designed to act as a link between tradition and modernity. The shapes are less rigorous, softer and more welcoming, and the overall lighter image is accentuated by the simple, airy design of the metal feet. Having lots of compositional pieces to work with means you can configure the right solution for each home.**

”



“

Una nuova profondità trasforma il concetto di living e permette di personalizzare ed adattare COPENAGHEN alle nuove esigenze di vita quotidiana. Il divano diventa il fulcro di molte attività quotidiane, studiare, leggere, lavorare, riposarsi e stare con gli amici, oggi tutto è possibile grazie al nuovo comfort ed alla nuova profondità maggiorata che permette di personalizzare ed adattare il prodotto alle esigenze di vita desiderate. Sedute lineari e sincere, ricche di contenuti sartoriali che valorizzano un patrimonio genetico aziendale fatto di ricerca ed artigianalità.

New depth transforms the living space concept and allows you to customise and adapt COPENAGHEN to the needs of everyday modern life. the sofa is the cornerstone of many daily activities: studying, reading, working, relaxing and spending time with friends. Today, anything is possible thanks to new comfort and increased depth, to customise and adapt the product to your everyday needs. Straightforward, linear seats, rich in sartorial details underline the company's DNA made up of research and craftsmanship.

”

Enrico Cesana





## **BRUNA VACCHER**

Inizia l'attività professionale nel 1990, dopo la laurea in architettura presso lo IUAV di Venezia e fonda lo studio Modacasa atelier architettura. Molteplici sono le esperienze nel campo dell'architettura, direzione artistica e design nel settore dell'arredamento.

She began her professional career in 1990, after graduating in Architecture from the IUAV in Venice, founding Modacasa, an architectural studio. She has a wealth of experience in the fields of architecture, artistic management and furniture design.

**RELIEF** / p. 14-27, 43, 58-59, 62-67, 70, 74, 77-78, 82, 86-93

“

Il segno grafico di questo tappeto è dato dal gioco di 2 tessiture diverse che combinate con l'effetto vibrante della viscosa e la lavorazione a mano eseguita negli antichi telai indiani, ne danno un sapore caldo e contemporaneo.

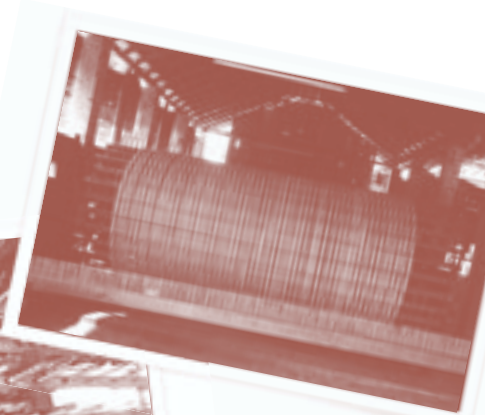

Two different weaves combine to give this rug its pattern. It has a warm yet contemporary feel thanks to the shimmering viscose and handcrafted detailing created on ancient Indian looms.

”

Bruna Vaccher













**CALIFORNIA** divano / sofa  
Tessuto Fado 26 / Fado 26 fabric  
L356 P125 H84

**MOCA** tavolino / occasional table  
Struttura laccato Nero opaco,  
piano laccato micalizzato Oro /  
Structure in matt Nero lacquered,  
Top in Micalyzed Oro laquered  
L60 P60 H45,4

**WOK** tavolino / occasional table  
Laccato Nero opaco / Matt Nero  
lacquered  
L27,5 P27,5 H50

**RAKU** poltrona / armchair  
Tessuto Nina 31 / Nina 31 fabric  
L84 P69 H75

**RAKU** pouf  
Tessuto Nina 31 / Nina 31 fabric  
L67 P49 H41,5

# CALIFORNIA

Divano / Sofa  
design Enrico Cesana

**Il divano CALIFORNIA si arricchisce con penisole e moduli che escono dalla logica dell'ortogonalità e creano sedute conviviali e adatte a un'idea di living meno schematica e formale, invece più aperta e accogliente.**

The CALIFORNIA sofa features lounge end units and modules that go beyond the idea of square right angles. They create convivial seating arrangements suitable for a less schematic and formal idea of a living room that is more open and welcoming.

El sofá CALIFORNIA se completa con penínsulas y módulos que rompen con las reglas de la perpendicularidad y crean asientos para disfrutar en compañía, adaptados a un concepto de salón menos esquemático y formal, más abierto y acogedor.

Le canapé CALIFORNIA s'enrichit de péninsules et modules qui sortent de la logique de l'orthogonalité et créent des sièges conviviaux et adaptés à une idée de living moins schématique et formelle et plus ouverte et accueillante.

Das Sofa CALIFORNIA wird durch Liege-Inseln und Module ergänzt, die die rechtwinkelige Logik des Designs aufbrechen und Sitzflächen für ein gemütliches Zusammensein schaffen und ein offenes und freundliches Ambiente schaffen, das weniger schematisch und formal erscheint.

Диван CALIFORNIA дополнен полуостровными элементами и модулями, которые следуют логике прямоугольности и создают удобную для сидения мебель, подходящую для менее схематичной и формальной и в то же время – более открытой и уютной концепции гостиной.







**CALIFORNIA** divano / sofa  
Pelle Lord 9120 / 9120 Lord  
leather  
L401,3 P147,2 H84

**MOCA** tavolino / occasional  
table  
Struttura laccato Nero opaco,  
piano Fashion wood rovere  
Fossile, laccato Nero opaco /  
Structure in matt Nero  
lacquered, Top in Fashion  
wood Fossile oak, matt Nero  
lacquered  
L60 P60 H45,4  
L90 P90 H37

**WOK** tavolino / occasional table  
Laccato Nero opaco / Matt Nero  
lacquered  
L27,5 P27,5 H50

**DENNY** pouf  
Pelle Lord 9120 / 9120 Lord  
leather  
L85 P85 H37

## RAKU

Collezione di sedute / Seat collection  
design Gordon Guillaumier

**La collezione di sedute imbottite RAKU – che comprende poltrona + pouf, divanetto, sedia e panca – ha un’immagine contemporanea ed essenziale. Seduta e schienale sono definiti da volumi semplici e arrotondati. Il piede, altrettanto essenziale, è formato da un tubo verticale che sembra solo appoggiato all’esterno dei volumi. La panca imbottita prevede anche un bracciolo in legno che la divide trasversalmente creando un funzionale piano di appoggio. Disponibile con rivestimento in pelle e in tessuto, RAKU è perfetta per regalare un tocco di comfort alla zona giorno, come alla zona notte.**

The RAKU collection of upholstered seats – which includes an armchair + footstool, small sofa, chair and bench – has a simple, contemporary look. The seat and back are defined by simple, rounded volumes. The equally simple leg is formed of a vertical bar that looks like it is resting against the outer edge of the chair back. The upholstered bench also has a wooden armrest that divides it widthways, creating a functional surface for resting things on. Available with leather and fabric upholstery, RAKU is perfect for adding a touch of comfort to the lounge and bedroom.

La colección de asientos tapizados RAKU – que abarca butaca + puff, sofá, silla y banqueta— ofrece una imagen moderna y sobria. El asiento y el respaldo están definidos por volúmenes simples y redondeados. Las patas, igualmente sencillas, están formadas por un tubo vertical que parece apoyarse simplemente por fuera de los volúmenes. La banqueta tapizada incluye también un reposabrazos de madera que la divide en sentido transversal, creando una superficie de apoyo funcional. Disponible con revestimiento de piel y de tejido, RAKU es perfecta para aportar un toque de confort a la zona de día, como en la zona de noche.

La collection de sièges rembourrés RAKU – qui comprend fauteuil + pouf, petit canapé, chaise et banquette – a une image contemporaine et essentielle. Assise et dossier sont définis par des volumes simples et arrondis. Le pied, tout autant essentiel, est formé par un tube vertical qui semble seulement posé à l'extérieur des volumes. La banquette rembourrée prévoit également un accoudoir en bois qui la divise transversalement en créant un plan d'appui fonctionnel. Disponible avec revêtement en cuir et en tissu, RAKU est parfait pour offrir une touche de confort à la zone jour, tout comme à la zone nuit.

Die Polstersitzkollektion RAKU steht mit ihren Sesseln + Polsterhockern, Sofas, Stühlen und Bänken für ein modernes und schlichtes Design. Sitz und Rückenlehne werden durch einfache und abgerundete Volumen definiert. Das ebenso schlicht gehaltene Bein besteht aus einem vertikalen Rohr, das auf der Außenseite der Volumen aufzuliegen scheint. Die gepolsterte Bank wird durch eine Armlehne aus Holz ergänzt, die sie quer unterteilt und so eine funktionale Auflagefläche schafft. RAKU ist mit Leder- und Stoffpolsterung erhältlich und eignet sich perfekt, um sowohl dem Wohn- als auch dem Schlafbereich einen Hauch von Komfort zu verleihen.

Collezione di sedute imbottite RAKU, inclusa la sedia + pouf, il divanetto, il tavolo e la panca, si distingue per la sua immagine contemporanea ed essenziale. Seduta e schienale sono definiti da volumi semplici e arrotondati. Il piede, altrettanto essenziale, è formato da un tubo verticale che sembra solo appoggiato all'esterno dei volumi. La panca imbottita prevede anche un bracciolo in legno che la divide trasversalmente creando un funzionale piano di appoggio. Disponibile con rivestimento in pelle e in tessuto, RAKU è perfetta per regalare un tocco di comfort alla zona giorno, come alla zona notte.







**FYRA** tavolo / table  
Fashion wood rovere Carbone /  
Fashion wood Carbone oak  
L200 P100 H75,4

**RAKU** sedia / chair  
Pelle Lord 9120 / Lord 9120  
leather  
L55,5 P55 H80





**RAKU** divanetto / sofa  
Tessuto Regal E047 / Regal  
E047 fabric  
L158 P69 H75

**MALMO** tavolino / occasional  
table  
Struttura Moka Shine, Piano  
Fashion wood rovere Naturale  
/ Structure in Moka Shine, Top  
in Fashion wood Naturale oak  
L42 P42 H50





**RAKU** poltrona / armchair  
Tessuto Nina 6 / Nina 6 fabric  
L84 P69 H75

**NEYŌ** tavolino / occasional  
table  
Struttura Moka Shine, Piano  
Marmo Carrara / Moka Shine  
structure, Top Carrara marble  
L60 P38 H42













# NEVADA

Divano / Sofa  
design Enrico Cesana

**NEVADA è un divano componibile che con la sua immagine sobria e informale esprime il perfetto equilibrio tra tradizione e contemporaneità. Le forme sono classiche ma la particolare geometria del bracciolo, la dimensione dei cuscini seduta, e l'essenzialità dei piedini in metallo rimandano definitivamente al gusto contemporaneo. La varietà dei moduli disponibili e la possibilità di rivestimento in tessuto e in pelle, rendono NEVADA un divano adatto agli spazi e agli stili più diversi.**

NEVADA is a modular sofa that, with its simple, informal look, expresses a perfect balance between tradition and modernity. The shapes are classic but the unusual geometry of the armrests, the size of the seat cushions, and the simplicity of the metal feet definitely evoke a contemporary flavour. The variety of modules available and the fabric or leather upholstery make NEVADA a sofa that suits very different rooms and styles.

NEVADA es un sofá modular que, con su imagen sobria e informal, transmite el perfecto equilibrio entre tradición y modernidad. Sus formas son clásicas, pero la particular forma del reposabrazos, el tamaño de los cojines de asiento y la sencillez de las patas de metal evocan claramente un gusto moderno. La variedad de los módulos disponibles y la posibilidad de revestimiento de tejido o de piel hacen de NEVADA un sofá ideal para los espacios y estilos más diversos.

NEVADA est un canapé modulaire qui avec son image sobre et informelle exprime le parfait équilibre entre la tradition et la contemporanéité. Les formes sont classiques mais la géométrie particulière de l'accoudoir, la dimension des coussins de l'assise et l'essentiel des pieds en métal renvoient définitivement au goût contemporain. La variété des modules disponibles et la possibilité de revêtement en tissu et en cuir font de NEVADA un canapé adapté aux espaces et aux styles les plus divers.

NEVADA ist ein modulares Sofa, das mit seinem nüchternen und informellen Erscheinungsbild die perfekte Balance zwischen Tradition und Moderne herstellt. Die Formen sind klassisch, aber die besondere Form der Armlehne, die Größe der Sitzkissen und die Schlichtheit der Metallfüße setzen moderne Akzente. Die Vielfalt der verfügbaren Module und die Möglichkeit der Bespannung mit Stoff und Leder machen NEVADA zu einem Sofa, das sich für die unterschiedlichsten Räume und Stile eignet.

NEVADA – это модульный диван, который своим строгим и неформальным стилем выражает идеальное равновесие между традицией и современностью. У него классические формы, тем не менее, особая геометрия подлокотника, размер подушек для сидения и металлические ножки без каких-либо излишеств определенно несут в себе дух современности. Разнообразие предлагаемых модулей и возможность обивки тканью и кожей позволяют использовать диван NEVADA для самых разных по стилистике интерьеров.







**NEVADA** divano / sofa  
Tessuto Fado 2 / Fado 2 fabric  
L470,4 P285 H81,7

**NEVADA** pouf  
Tessuto Dalì 04 / Dalì 04 fabric  
L185 P86 H44

**NEYŌ** tavolino / occasional  
table  
Struttura Moka Shine, Piano  
Mamo Carrara /  
Structure Moka Shine, Top in  
Carrara Marble  
L60 P38 H42

**DENNY** pouf  
Pelle Lord 9120 / 9120 Lord  
leather  
L85 P85 H37

**NEVADA** divano / sofa  
Tessuto Fado 2 / Fado 2 fabric  
L302 P146 H81,7

**MOCA** tavolino / occasional table  
Struttura laccato Nero opaco,  
piano Fashion wood rovere  
Fossile /  
Structure in matt Nero lacquered,  
Top in Fashion wood Fossile oak  
L90 P90 H37

**NEVADA** pouf  
Tessuto Dalì 04 / Dalì 04 fabric  
L185 P86 H44







## KENDO

Credenza / Sideboard  
design Meneghello Paoletti Associati

**KENDO è una credenza caratterizzata da un particolare gioco geometrico delle ante: ciascuna anta presenta un taglio a 30° che la divide in due parti non perfettamente complanari ma lievemente disassate, regalando alla superficie un raffinato effetto di chiaroscuro. KENDO è proposto nelle finiture nobilitate, Fashion wood e laccati. È eventualmente disponibile anche con ante, struttura e top in finiture o colore differenti.**



KENDO is a sideboard with unusual geometric doors: each one has a 30° cut that divides it into two parts that are not on exactly the same plane but instead slightly off-centre, lending the surface a refined light and shade effect. KENDO is available in a surfaced, Fashion Wood or lacquered finish. It is also available with the doors, frame and top in different finishes or colours.

KENDO es un aparador caracterizado por un particular juego geométrico de las puertas: cada una de ellas presenta un corte a 30° que la divide en dos partes no perfectamente coplanares, sino levemente desalineadas, confiriendo a la superficie un elegante efecto de claroscuro. KENDO está disponible en los acabados ennoblecidos, Fashion wood y lacados. Bajo pedido, las puertas, la estructura y la encimera pueden tener acabados o colores diferentes.

KENDO est un bahut caractérisé par un jeu géométrique des portes particulier : chaque porte présente une découpe à 30° qui la divise en deux parties non parfaitement coplanaires mais légèrement désaxées, en offrant à la surface un raffiné effet de clair-obscur. KENDO est proposé dans les finitions mélaminés, Fashion wood et laquées. Éventuellement, il est également disponible avec portes, structure et plan dans des finitions et coloris différents.

KENDO ist ein Sideboard, das sich durch ein besonderes geometrisches Spiel auf der Front auszeichnet: Jede Tür hat einen 30°-Schnitt, der sie in zwei Teile teilt, die nicht perfekt komplanar, sondern leicht versetzt sind, wodurch auf der Oberfläche ein raffiniertes Spiel mit Licht und Schatten entsteht. KENDO ist erhältlich in den Ausführungen Melamin, Fashion Wood und lackiert. Türen, Korpus und Platten können zudem in unterschiedlichen Ausführungen oder Farben geliefert werden.

KENDO – это тумба с характерным геометрическим рисунком дверей: каждая с 30-градусным наклонным разрезом, разделяющим ее на две части, которые не идеально лежат в одной плоскости, а слегка смещены, что придает их поверхности изысканный светотеновой рисунок. KENDO предлагается в ламинированных отделках, Fashion wood и крашеных. Она также предлагается с дверцами, корпусом и столешницей в различных отделках или цветах.





**KENDO** credenza / sideboard  
Struttura Fashion wood rovere  
Fossile, ante laccato lucido  
Modica / Fashion wood Fossile  
oak structure, doors in high  
gloss Modica laquered  
L210 P50 H78

**FYRA** tavolo / table  
Fashion wood rovere Carbone /  
Fashion wood Carbone oak  
L200 P100 H75,4

**RAKU** sedia / chair  
Pelle Lord 9120 / Lord 9120  
leather  
L55,5 P55 H80

**ESAGONA** specchiera / mirror  
Cornice Moka Shine / Moka  
Shine frame  
L80 P5 H69,3



**KENDO** credenza / sideboard

**NEWS 2019**

**Alf DaFrè**







**RAKU** divanetto / sofa  
Tessuto Regal E003 / Regal  
E003 fabric  
L158 P69 H75

**RAKU** poltrona / armchair  
Tessuto Nina 28 / Nina 28  
fabric  
L84 P69 H75







**RAKU** divanetto / sofa  
Tessuto Regal E048 / Regal  
E048 fabric  
L158 P69 H75





**RAKU** panca con bracciolo /  
bench with armrest  
Tessuto Regal E048, bracciolo  
Fashion wood rovere Naturale  
/ Regal E048 fabric, Armrest in  
Fashion wood Naturale oak  
L150 P68 H53





**RAKU** divanetto / sofa  
Tessuto Regal E038 / Regal  
E038 fabric  
L158 P69 H75

**RAKU** poltrona / armchair  
Tessuto Nina 4 / Nina 4 fabric  
L84 P69 H75





**RAKU** poltrona / armchair  
Tessuto Nina 23 / Nina 23 fabric  
L84 P69 H75

**NEYŌ** tavolino / occasional  
table  
Struttura Moka Shine, Piano  
Marmo Carrara / Moka Shine  
structure, Top Carrara marble  
L60 P38 H42



NEWS 2019

RAKU collezione di sedute / seat collection

DaFle





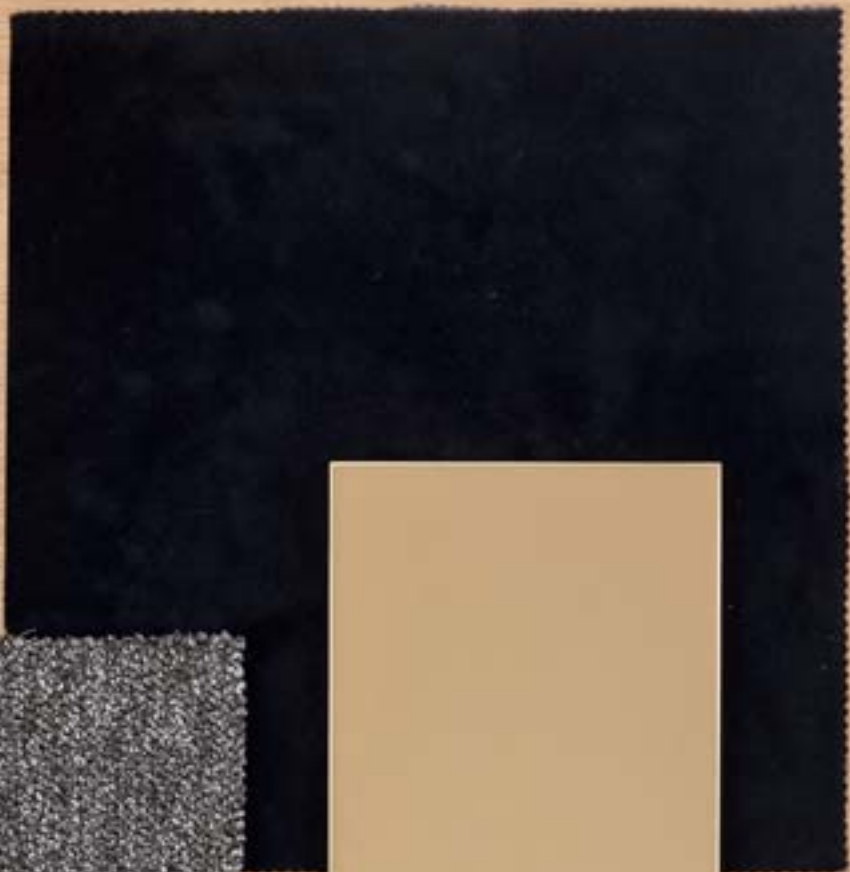





**Il tavolo è caratterizzato da geometrie sofisticate e da “stacchi” tra gli elementi che rendono la composizione molto espressiva. Il piano, definito da una linea mista a metà tra retta e curvilinea, è diviso in 4 quadranti che creano con le venature del legno un motivo tipico della tradizione ebanista. Una piastra di ferro collega e contemporaneamente separa visivamente il piano dalle 4 gambe a sezione conica irregolare, più rotonda alla base e più ovalizzata all'estremità superiore. FYRA è proposto in tutte le finiture di Fashion wood e roveri laccati.**

The table features sophisticated geometry and intervals between the elements that make the composition very expressive. The top, defined by a line that is a mixture of half straight and half curvilinear, is divided into 4 quarters which create a typical design from traditional carpentry with the wood grain. An iron plate connects and, at the same time, visually separates the top from the 4 legs which have an irregular conical cross-section, rounder at the base and more oval at the top end. FYRA comes in all the Fashion Wood and matt lacquered oak finishes.

La mesa se caracteriza por formas sofisticadas y por “separaciones” entre los elementos, que otorgan una gran expresividad a la composición. El sobre, definido por una línea mixta a mitad de camino entre recta y curva, está dividido en 4 cuadrantes que, con las vetas de la madera, crean un motivo típico de la tradición ebanista. Una placa de hierro une y separa visualmente al mismo tiempo el sobre y las 4 patas de sección cónica irregular, más redonda en la parte inferior y más ovalada en el extremo superior. FYRA está disponible en todos los acabados de Fashion wood y roble lacados mate.

La table est caractérisée par des géométries sophistiquées et par des contrastes entre les éléments qui rendent a composition très expressive. Le plateau, défini par une ligne mixte à moitié entre droite et incurvée, est divisé en 4 cadrans qui créent avec les veinures du bois un motif typique de la tradition ébéniste. Une plaque de fer relie et en même temps sépare visuellement le plateau des 4 pieds à section conique irrégulière, plus ronde à la base et plus ovalisée à l'extrémité supérieure. FYRA est proposée dans toutes les finitions de Fashion wood et chêne laqués mats.

Der Tisch zeichnet sich durch raffinierte Formen und „Brüche“ zwischen den Elementen aus, die der Komposition einen starken Charakter verleihen. Die Platte hat einen Schwung, spielt mit geraden und abgerundeten Linien spielt, und ist in 4 Elemente unterteilt, deren Maserung ein klassisches Motiv aus der Tischlerei ergibt. Eine Eisenplatte verbindet und trennt gleichzeitig die Tischplatte von den 4 kegelförmigen Beinen, die sich nach unten hin verjüngen. FYRA ist in allen Ausführungen von Fashion Wood und Eiche matt lackiert erhältlich.

Стол характеризуется сложной геометрией и «контрастами» между элементами, которые делают композицию очень выразительной. Поверхность столешницы, определяемая комбинированной линией – наполовину прямой, наполовину кривой, разделена на 4 квадрата, которые создают вместе с текстурой дерева типичный для мебели традиции рисунок. Металлическая пластина соединяет и в то же время визуально отделяет столешницу от 4 ножек с неравномерным коническим сечением, более круглым в основании и более овальным в верхней части. FYRA предлагается во всех отделках Fashion wood и Дуб крашенный матовый.





**FYRA** tavolo / table  
Fashion wood rovere Naturale /  
Fashion wood Naturale oak  
L278,5 P104,5 H75,4

**CORIUM** sedia / chair  
Tessuto Fado 26 / Fado 26  
fabric  
L50,5 P55 H80











**FYRA** tavolo / table

NEWS 2019



**FYRA** tavolo / table  
Fashion wood rovere Naturale /  
Fashion wood Naturale oak  
L278,5 P104,5 H75,4

**CORIUM** sedia / chair  
Tessuto Fado 26 / Fado 26  
fabric  
L50,5 P55 H80

Alf DaFre®

## **RELIEF**

Collezioni tappeti / Rugs collection  
design Bruna Vaccher

**Le proprietà brillanti della viscosa di bamboo sono utilizzate al meglio in questo esercizio di tessitura manuale contemporanea.**

**Il volume di questa tessitura, ottenuto dai telai antichi ancora disponibili in India, risulta essere compatto, seducente e vibrante alla luce.**

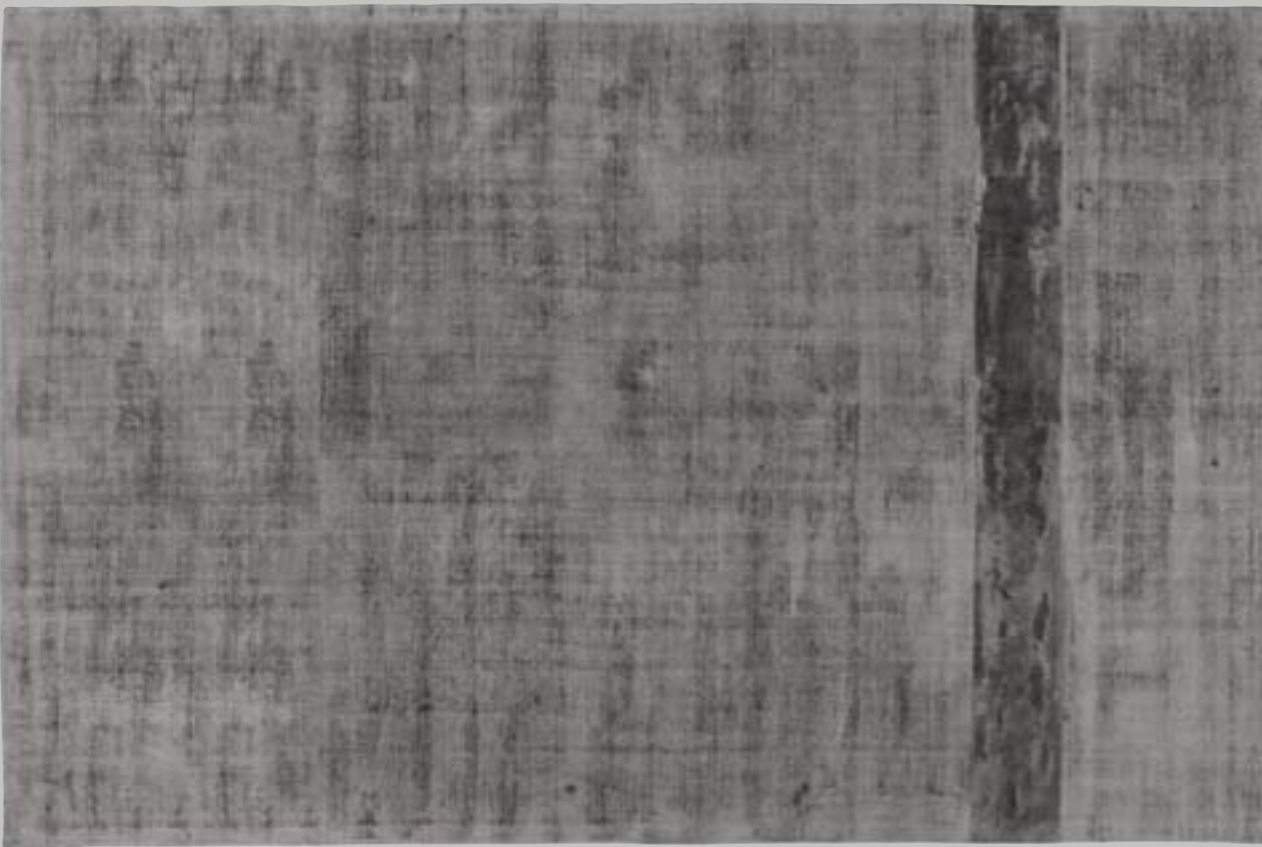

The shiny properties of bamboo viscose can be fully appreciated in this contemporary manual weave. Created using ancient looms still found in India, this weave is compact, seductive and glimmers in the light.

Las propiedades brillantes de la viscosa de bambú se aprovechan al máximo en este tejido de elaboración manual y moderna. El volumen de este tejido, logrado mediante antiguos telares aún disponibles en la India, resulta compacto, cautivador y vibrante a la luz.

Les propriétés brillantes de la viscosse de bambou sont utilisées au mieux dans cet exercice de tissage manuel contemporain. Le volume de ce tissage, obtenu à partir de métiers à tisser antiques encore disponibles en Inde, s'avère être compact, séduisant et vibrant à la lumière.

Die brillanten Eigenschaften von Bambusviskose kommen bei diesem handgewebten modernen Teppich bestens zur Geltung. Dieses Produkt entsteht auf alten, noch in Indien eingesetzten Webstühlen und überzeugt durch eine kompakte Webart, die verführerisch und lebendig mit dem Licht spielt.

Превосходные характеристики бамбуковой вискозы наилучшим образом выражены в этом образце современного ручного прядения. Объем такого прядения, достигаемый на античных станках, до сих пор используемых в Индии, является компактным, обольстительным и вибрирующим на свет.













**La linea del letto NEYŌ si ispira alla forma organica dei ciottoli di fiume levigati dall'acqua. Il disegno morbido che definisce sia gli elementi imbottiti sia i doppi ripiani regala alla composizione l'aria avvolgente e funzionale di un letto a cui non servono altri complementi. Il letto può essere rivestito con tutti i tessuti e le pelli disponibili in catalogo, i ripiani laterali sono proposti in Fashion wood, roveri laccati opachi o marmo di Carrara.**

The line of the NEYŌ bed is inspired by the organic shape of pebbles washed smooth by the flow of a river. The soft design of both the padded elements and the double shelf adds a welcoming, functional air to the composition. This bed needs no further complements. It can be upholstered in all the fabrics and leathers available in the catalogue, while the side shelves are available in Fashion Wood, matt lacquered oak or Carrara marble.

La línea de la cama NEYŌ se inspira en la forma orgánica de los cantos rodados de río, pulidos por el agua. El suave dibujo que define tanto los elementos tapizados como las dobles baldas infunde a la composición el aspecto envolvente y funcional de una cama que no necesita más complementos. La cama se puede revestir con todos los tejidos y pieles disponibles en el catálogo. Las baldas laterales están disponibles en Fashion wood, robles lacados mate o mármol de Carrara.

La ligne du lit NEYŌ s'inspire de la forme organique des galets de fleuve polis par l'eau. Le doux dessin qui définit aussi bien les éléments rembourrés que les doubles étagères offre à la composition l'aspect enveloppant et fonctionnel d'un lit qui n'a pas besoin d'autres compléments. Le lit peut être revêtu avec tous les tissus et les cuirs disponibles dans le catalogue. Les étagères latérales sont proposées en Fashion wood, chênes laqués mats ou marbre de Carrara.

Die Linie des Bettes NEYŌ ist inspiriert von der organischen Form der Flusskiesel mit ihrer vom Wasser geglätteten Oberfläche. Das weiche Design, das sowohl die Polster Elemente als auch die beiden Ablageflächen definiert, verleiht der Komposition eine einladende und doch funktionale Ausstrahlung eines Bettes, das kein weiteres Zubehör benötigt. Das Bett kann mit allen im Katalog erhältlichen Stoffen und Ledern bezogen werden. Die seitlichen Ablagen sind in Fashion Wood, Eiche matt lackiert oder Carrara-Marmor erhältlich.

Линии кровати NEYŌ вдохновлены органичной формой сглаженной водой речной гальки. Мягкий дизайн, который определяет как мягкие элементы кровати, так и двойные полки, придает всей композиции чарующий и функциональный вид, которой не нужны другие аксессуары. Кровать может быть отделана любыми тканями и кожей, представленными в каталоге. Боковые полки предлагаются из Fashion wood, матового крашеного дуба или мрамора Carrara.







**NEYŌ** letto / bed  
Comodino con doppia  
mensola / Night stand with  
double shelf  
Tessuto Trento 05, Fashion  
wood rovere Naturale,  
Marmo Carrara /  
Trento 05 fabric, Fashion  
wood Naturale oak, Carrara  
marble  
**L315,5 P220,3 H92,5**



**NEYŌ** letto / bed  
Comodino con cassetto rotante  
/ Night stand with turning chest  
Tessuto Trento 05, Fashion  
wood rovere Naturale, Marmo  
Carrara /  
Trento 05 fabric, Fashion wood  
Naturale oak, Carrara marble  
L315,5 P220,3 H92,5









**NEYŌ** letto / bed  
Comodino con doppia  
mensola / Night stand with  
double shelf  
Tessuto Trento 05, Fashion  
wood rovere Naturale,  
Marmo Carrara /  
Trento 05 fabric, Fashion  
wood Naturale oak, Carrara  
marble  
L315,5 P220,3 H92,5



# NEYŌ

Tavolino / Coffee table  
design Gordon Guillaumier

**Complemento ideale sia per la zona giorno che per la camera da letto il tavolino NEYŌ è caratterizzato dalla struttura in metallo finitura Moka Shine e il piano dalla linea curva disponibile nelle varianti Fashion wood, rovere laccati opachi o marmo di Carrara.**

The ideal complement for both the living area and the bedroom, the NEYŌ occasional table has a metal frame in the Moka Shine finish and a curved top available in Fashion Wood, matt lacquered oak or Carrara marble.

Complemento ideal tanto para la zona de día como para el dormitorio, la mesita NEYŌ se caracteriza por su estructura de metal en acabado Moka Shine y su sobre de línea curva disponible en las variantes Fashion wood, roble lacados mate o mármol de Carrara.

Complément idéal aussi bien pour la zone jour que pour la chambre à coucher, la table basse NEYŌ est caractérisée par la structure en métal finition Moka Shine et le plateau à la ligne arrondie disponible dans les versions Fashion wood, chênes laqués mats ou marbre de Carrara.

Der NEYŌ Couchtisch ist die ideale Ergänzung für den Wohn- und Schlafbereich und zeichnet sich durch die das Metallgestell in der Ausführung Moka Shine und die geschwungene Platte in Fashion Wood, Eiche matt lackiert oder Carrara-Marmor aus.

Столик NEYŌ, идеально подходящий как для гостиной, так и для спальни, характеризуется металлической структурой в отделке Moka Shine и столешницей с изогнутыми линиями. Он предлагается из Fashion wood, матового крашеного дуба или мрамора Carrara.





**NEYŌ** letto / bed  
Tessuto Trento 05 / Trento 05  
fabric  
L237,7 P220,3 H92,5

**NEYŌ** tavolino / coffee table  
Struttura Moka Shine, Piano  
Marmo Carrara /  
Moka Shine structure, Top in  
Carrara marble  
L60 P38 H42













## **COPENAGHEN**

Divano / Sofa  
design Enrico Cesana

**In aggiunta alle diverse varianti in catalogo, il divano COPENAGHEN è presentato oggi con una nuova profondità di 110 cm pensata per offrire una seduta più confortevole e idonea al relax in tutte le ore del giorno.**

In addition to the different varieties in the catalogue, the COPENAGHEN sofa now comes in a new depth of 110 cm designed to provide a more comfortable seat suitable for relaxing at all times of the day.

Además de las diversas variantes del catálogo, el sofá COPENAGHEN está disponible ahora con una nueva profundidad de 110 cm pensada para ofrecer un asiento más cómodo e ideal para el relax a cualquier hora del día.

En plus des différentes variantes du catalogue, le canapé COPENAGHEN est aujourd'hui présenté avec une nouvelle profondeur de 110 cm conçue pour offrir une assise plus confortable et adaptée au relax à toutes les heures de la journée.

Zusätzlich zu den Katalogvarianten ist das Sofa COPENAGHEN nun auch mit einer neuen Tiefe von 110 cm erhältlich, die für eine komfortablere Sitzfläche sorgt und zu jeder Tageszeit zum Entspannen einlädt.

В дополнение к различным версиям в каталоге, диван COPENAGHEN предлагается сегодня с новой глубиной 110 см, специально предусмотренной для того, чтобы предложить более удобный диван, подходящий для расслабления и отдыха в любое время суток.







**COPENAGHEN** divano / sofa  
Tessuto Rubens 06 / Rubens  
06 fabric  
L390 P110 H86

**COPENAGHEN** divano / sofa  
Tessuto St. Moritz 041 / St.  
Moritz 041 fabric  
L255 P90 H86

**MALMO** tavolino / occasional  
table  
Struttura Moka Shine, Piano  
Fashion wood rovere Naturale /  
Structure in Moka Shine, Top in  
Fashion wood Naturale oak  
L42 P42 H50  
Struttura Moka Shine, Piano  
Fashion wood rovere Ghiro /  
Structure in Moka Shine, Top in  
Fashion wood Ghiro oak  
L100 P100 H41,3  
Struttura Laccato opaco  
Origano, Piano Laccato lucido  
Origano / Structure in matt  
lacquered Origano, Top in high  
gloss lacquered Origano  
Struttura Laccato opaco Tè  
verde, Piano Rovere colore  
opaco Tè verde / Structure in  
Matt lacquered Tè verde, Top in  
Matt oak colour Tè verde  
L150 P50 H54,2

**RAKU** divanetto / sofa  
Tessuto Regal E047 / Regal  
E047 fabric  
L158 P69 H75















# JETTY

Letto / Bed  
design Gordon Guillaumier

**Il letto JETTY, caratterizzato dalla struttura in metallo tubolare finitura elettrocol, oggi viene integrato dalla versione con testiera in tessuto.**

The JETTY bed with a tubular metal frame in an Elettrocol finish is now complemented by a version with a fabric headboard.

La cama JETTY, caracterizada por su estructura de metal tubular en acabado elettrocol, se completa ahora con la versión que incluye cabecera en tejido.

Le lit JETTY, caractérisé par la structure en métal tubulaire finition elettrocol, est aujourd'hui intégré par la version avec tête de lit en tissu.

Das Bett JETTY, das sich durch das Gestell aus Metallrohr in Elettrocol auszeichnet, wird nun durch die Version mit Stoff-Kopfteil ergänzt.

Кровать JETTY, характеризующаяся металлическим трубчатым каркасом с отделкой elettrocol, теперь предлагается в новом варианте с тканевой головной спинкой.







**JETTY** letto / bed  
Testiera tessuto Doble 02,  
Struttura verniciato Elettrocol /  
Headboard in Doble 02 fabric,  
Structure in Elettrocol painted  
L174 P212,6 H94,5

**FIL** gruppo notte / bedgroup  
Laccato opaco Platino / Matt  
Platino lacquered  
L90 P48 H49,6

**ESAGONA** specchiera / mirror  
Cornice Moka Shine / Moka  
Shine frame  
L80 P5 H69,3

## **ESAGONA / DISCO**

Specchiere / Mirrors

**Le specchiere ESAGONA e DISCO, adatte ad ogni ambiente, hanno cornice in metallo finitura Moka Shine. Il modello DISCO è disponibile in tre misure.**

The mirrors ESAGONA and DISCO, suitable for any space, have a metal frame finished in Moka Shine. The DISCO model comes in three sizes.

Los espejos ESAGONA y DISCO, perfectos para cualquier espacio, tienen perfil de metal en acabado Moka Shine. El modelo DISCO está disponible en tres tamaños.

Les miroirs ESAGONA et DISCO, adaptés à tout espace ambiant, ont un cadre en métal finition Moka Shine. Le modèle DISCO est disponible en trois dimensions.

Die Spiegel ESAGONA und DISCO, die sich in jedem Ambiente zuhause fühlen, haben über einen Metallrahmen in Moka Shine. Das Modell DISCO ist in drei Größen erhältlich.

Зеркала ESAGONA и DISCO, подходящие для любой обстановки, имеют металлическую раму с отделкой Moka Shine. Модель DISCO предлагается трех размеров.

**RAKU** panca con bracciolo /  
bench with armrest  
Tessuto Regal 48, bracciolo  
Fashion wood rovere Naturale  
/ Regal 48 fabric, Armrest in  
Fashion wood Naturale oak  
L150 P68 H53

**DISCO** specchiera / mirror  
Cornice Moka Shine / Moka  
Shine frame  
L76,5 P5,5 H76,5  
L50 P50 H76,5





# Raku

design **Gordon Guillaumier**



## Materiali e finiture

Rivestimento:  
Tessuti / Pelle / Ecopelle  
Gambe in metallo:  
Verniciato Moka Shine

## Materials and finishes

Covering:  
Fabric / Leather / Ecoleather  
Metal legs:  
Painted Moka Shine

## Materiales y acabados

Revestimiento:  
Tejidos / Piel / Eco-piel  
Patas de metal:  
Barnizado Moka Shine

## Matériaux et finitions

Revêtement :  
Tissus / Cuir / Éco-cuir  
Pieds en métal :  
Verni Moka Shine

## Materialien und Ausführungen

Bezug:  
Stoff / Leder / Kunstleder  
Beinen aus Metall:  
Lackiert Moka Shine

## Материалы и варианты отделки

Обивка:  
Ткань / Кожа / Экокожа  
Металлические ножки:  
Крашенный Moka Shine

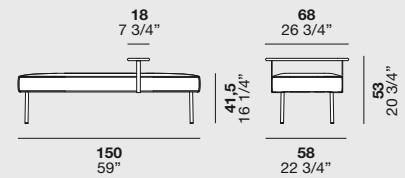
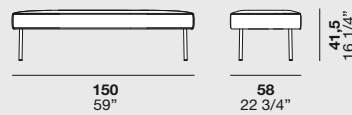
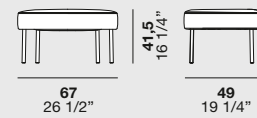
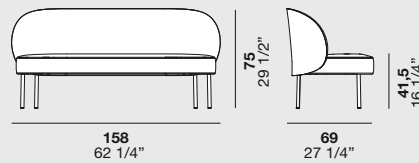
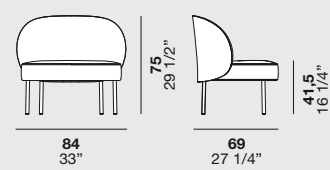
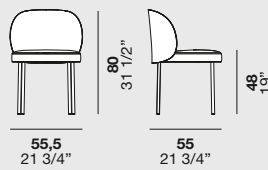

# Corium

design R.D.A.

/technical data



## Materiali e finiture

Rivestimento:  
Tessuti / Pelle / Ecopelle

-

## Materials and finishes

Covering:  
Fabric / Leather / Ecoleather

-

## Materiales y acabados

Revestimiento:  
Tejidos / Piel / Eco-piel

-

## Matériaux et finitions

Revêtement :  
Tissus / Cuir / Éco-cuir

-

## Materialien und Ausführungen

Bezug:  
Stoff / Leder / Kunstleder

-

## Материалы и варианты отделки

Обивка:  
Ткань / Кожа / Экокожа

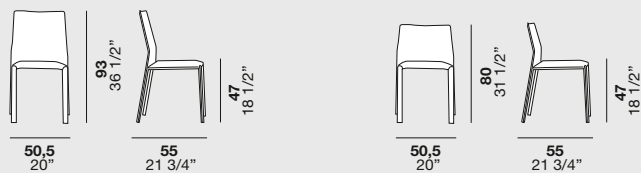

NEWS 2019

Alf DaFrè

# Kendo

design **Meneghello Paoletti Associati**



## Materiali e finiture

Basamento in metallo:

verniciato Moka Shine

Struttura e frontali:

Nobilitati / Fashion wood / Rovere laccati opachi /

Laccati opachi e lucidi / Laccati micalizzati

-

## Materials and finishes

Metal base:

Painted Moka Shine

Framework and fronts:

Surfaced / Fashion Wood / Matt lacquered oak

Matt and high-gloss lacquers / Micalised lacquered

-

## Materiales y acabados

Base de metal:

barnizado Moka Shine

Estructura y frontales:

Ennoblecidos / Fashion wood / Roble lacados mate

Lacados mate y brillantes / Lacados micalizada

-

## Matériaux et finitions

Piètement en métal :

verni Moka Shine

Structure et façades :

Mé laminés / Fashion wood / Chêne laqués mats

Laqués mats et brillants / Laqués micalisée

-

## Materialien und Ausführungen

Untergestell aus Metall:

lackiert Moka Shine

Korpus und Fronten:

Melamin / Fashion Wood / Eiche matt lackiert

Glänzend und matt lackiert / Mischbarer Lackiert

-

## Материалы и варианты отделки

Металлическое основание:

крашенный Moka Shine

Каркас и фронтальные панели:

Ламинированный / Fashion wood / Дуб крашенный

матовый / Крашенный матовый и глянцевый

/ Микализированный лак

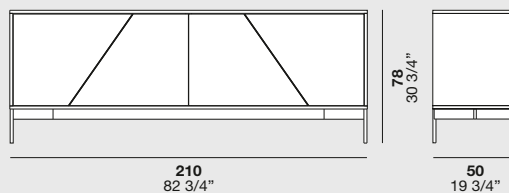
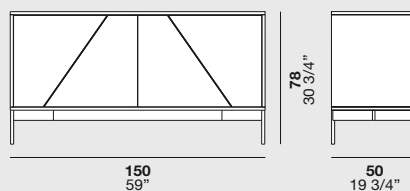

# Disco

design R.D.A.

## Materiali e finiture

Cornice metallo: Verniciato Moka Shine

-

## Materials and finishes

Metal frame: Painted Moka Shine

-

## Materiales y acabados

Perfil de metal: Barnizado Moka Shine

-

## Matériaux et finitions

Cadre en métal : Verni Moka Shine

-

## Materialien und Ausführungen

Metallrahmen: Lackiert Moka Shine

-

## Материалы и варианты отделки

Металлическая рама: Крашенный Moka Shine

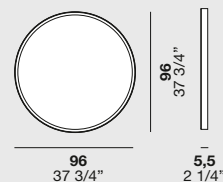
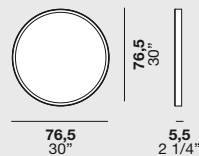
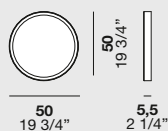

# Esagona

design R.D.A.

## Materiali e finiture

Cornice metallo: Verniciato Moka Shine

-

## Materials and finishes

Metal frame: Painted Moka Shine

-

## Materiales y acabados

Perfil de metal: Barnizado Moka Shine

-

## Matériaux et finitions

Cadre en métal : Verni Moka Shine

-

## Materialien und Ausführungen

Metallrahmen: Lackiert Moka Shine

-

## Материалы и варианты отделки

Металлическая рама: Крашенный Moka Shine

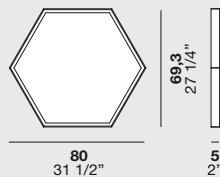

# Nevada

design **Enrico Cesana**

## Materiali e finiture

Rivestimento:  
Tessuti / Pelle / Ecopelle  
Gambe in metallo:  
Verniciato Moka Shine  
-

## Materials and finishes

Covering:  
Fabric / Leather / Ecoleather  
Metal legs:  
Painted Moka Shine  
-

## Materiales y acabados

Revestimiento:  
Tejidos / Piel / Eco-piel  
Patas de metal:  
Barnizado Moka Shine  
-

## Matériaux et finitions

Revêtement :  
Tissus / Cuir / Éco-cuir  
Pieds en métal :  
Verni Moka Shine  
-

## Materialien und Ausführungen

Bezug:  
Stoff / Leder / Kunstleder  
Beinen aus Metall:  
Lackiert Moka Shine  
-

## Материалы и варианты отделки

Обивка:  
Ткань / Кожа / Экокожа  
Металлические ножки:  
Крашенный Moka Shine  
-

## Divani

Sofas / Sofás / Canapés / Sofas / Диваны

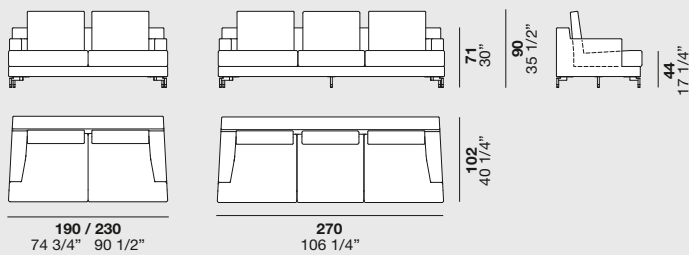

## Moduli terminali sx o dx

Left or Right facing end units / Módulos terminales izda. o dcha. / Modules terminaux gauches ou droits / Abschlusselemente li. oder re. / Терминальные лев. или прав. модули

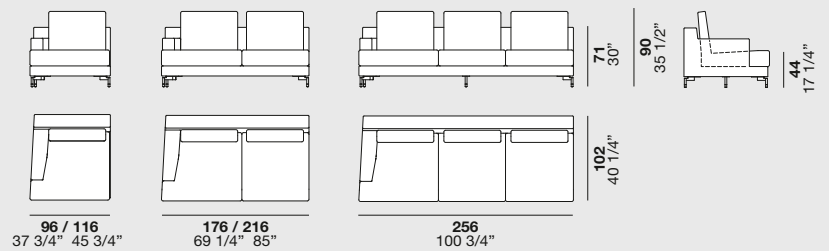

## Moduli centrali

Central units / Módulos centrales / Modules centraux / Mittelelemente / Центральные модули

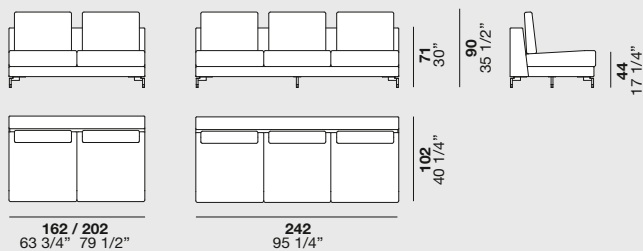

## Angoli

Corner units / Módulos de esquina / Angles / Eckelemente / Угловые модули

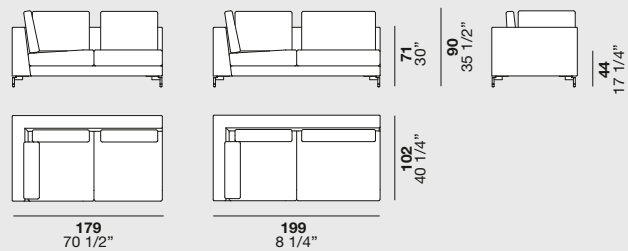



**Moduli penisola**

Peninsula units / Módulos peninsula / Modules péninsule / Halbinsel-Module / Полуостровные модули

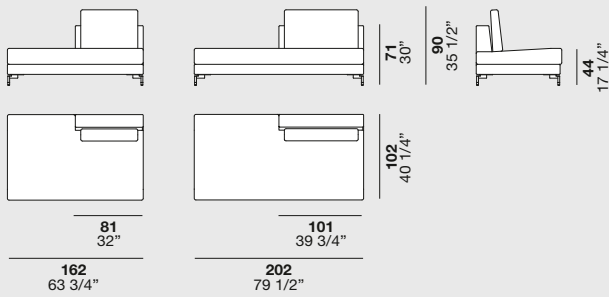

**Moduli penisola inclinata**

Angled lounge units / Módulos peninsula inclinada / Modules péninsule inclinée / Module schräge Liege-Insel / Полуостровные наклонные модули

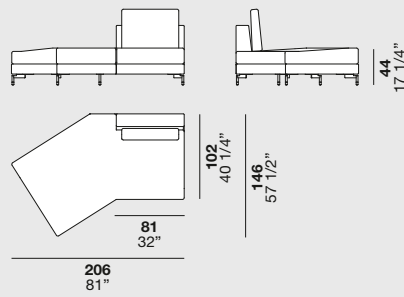

**Pouf**

Pouf / Puffs / Pouf / Polsterhocker / Пуфы

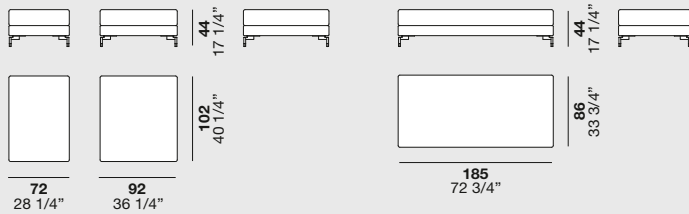

**Chaise longue sx o dx**

Left or Right facing chaise longue / Chaise longue izda. o dcha. / Chaise longue gauche ou droite / Chaiselongue li. oder re. / Лев. или прав. шезлонги

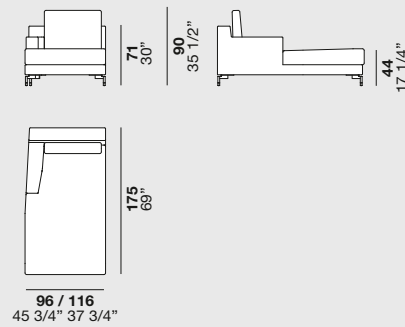



**Esempi di composizioni**

Composition examples / Ejemplos de composiciones / Exemples de compositions /  
Beispiele für Zusammenstellungen / Примеры композиций

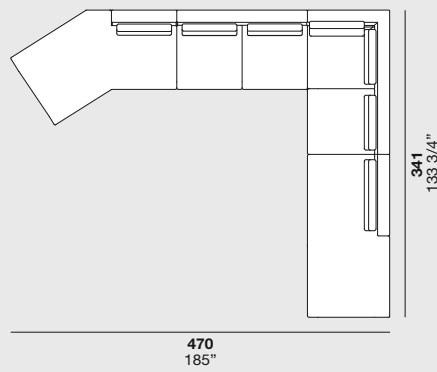
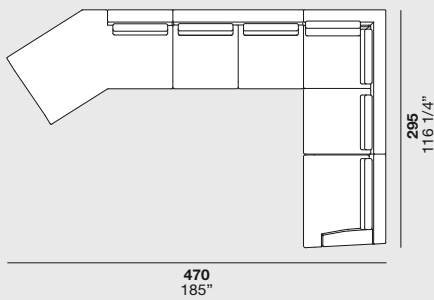
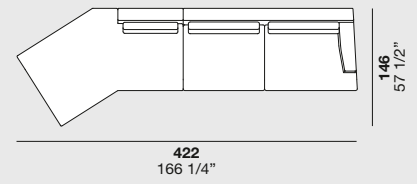
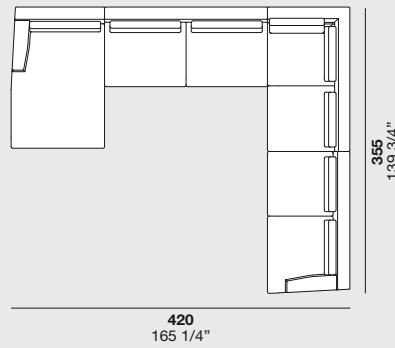
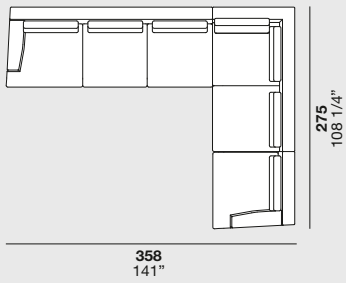
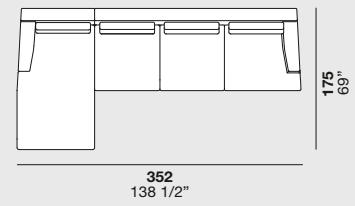
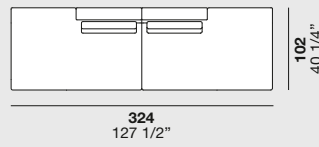
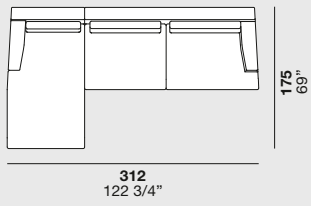
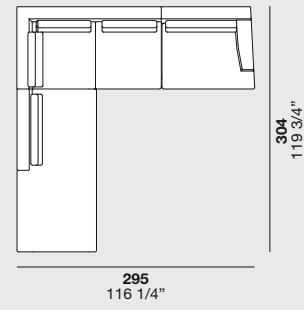
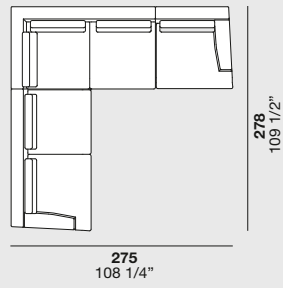
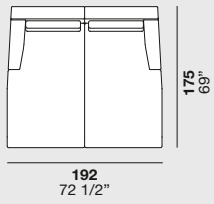



# California

design **Enrico Cesana**



## Materiali e finiture

Rivestimento:  
Tessuti / Pelle / Ecopelle

-

## Materials and finishes

Covering:  
Fabric / Leather / Ecoleather

-

## Materiales y acabados

Revestimiento:  
Tejidos / Piel / Eco-piel

-

## Matériaux et finitions

Revêtement :  
Tissus / Cuir / Éco-cuir

-

## Materialien und Ausführungen

Bezug:  
Stoff / Leder / Kunstleder

-

## Материалы и варианты отделки

Обивка:  
Ткань / Кожа / Экокожа

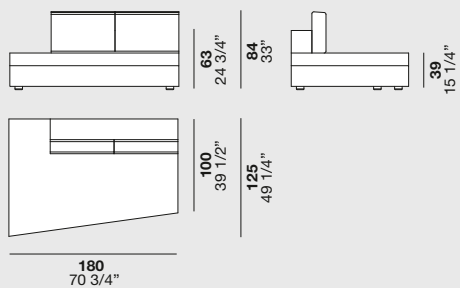
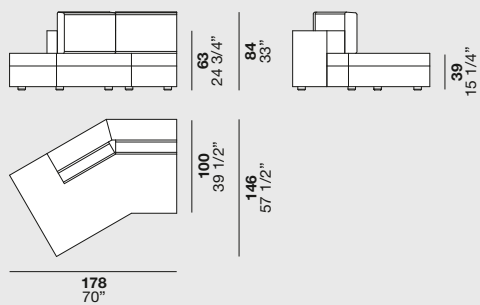

**Esempi di composizioni**

Composition examples / Ejemplos de composiciones / Exemples de compositions /  
Beispiele für Zusammenstellungen / Примеры композиций

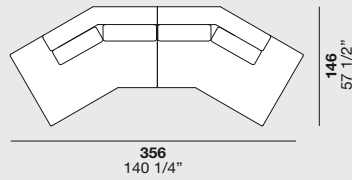
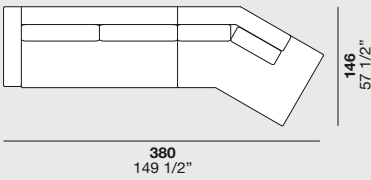
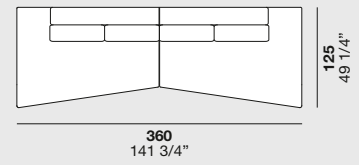
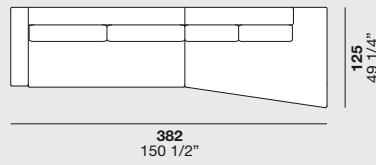
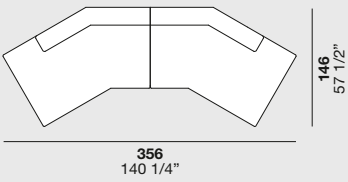
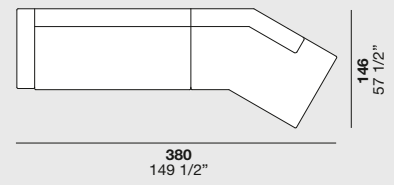
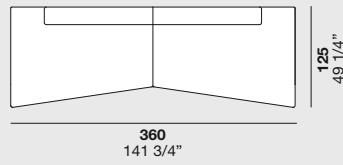
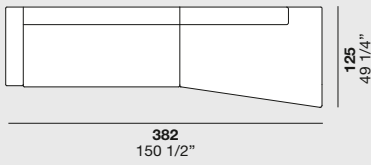

# Copenhagen

design **Enrico Cesana**



## Divani

Sofas /Sofás /Canapés / Sofas / Диваны

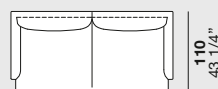
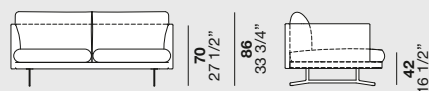

180 / 200 / 220 / 240 / 260  
70 3/4" 78 3/4" 86 1/2"  
94 1/2" 102 1/4"

## Divani per angolo sx o dx

Left or Right facing sofas for corner /sofás para esquina izda. o dcha. /canapés pour coin gauche ou droit /Sofas für die li. oder re. Ecke /диваны для левого или правого угла

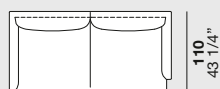

180 / 200 / 220 / 240 / 260  
70 3/4" 78 3/4" 86 1/2"  
94 1/2" 102 1/4"

## Moduli terminali sx o dx

Left or Right facing end units /Módulos terminales izda. o dcha. / Modules terminaux gauches ou droits /Abschlusselemente li. oder re. / Терминальные лев. или прав. модули

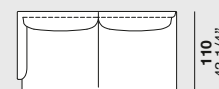

175 / 195 / 215 / 235 / 255  
69" 76 3/4" 84 3/4"  
92 1/2" 100 1/2"

## Chaise longue sx o dx

Left or Right facing chaise longue / Chaise longue izda. o dcha. / Chaise longue gauche ou droite / Chaiselongue li. oder re. / Лев. или прав. шезлонги

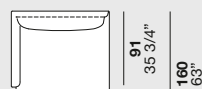
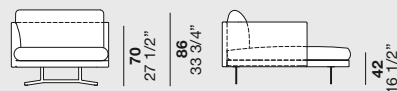

110  
43 1/4"

## Moduli penisola

Peninsula units / Módulos península / Modules péninsule / Halbinsel-Module / Полуостровные модули



110  
43 1/4"

170  
67"

## Moduli centrali

Central units / Módulos centrales / Modules centraux / Mittelelemente / Центральные модули

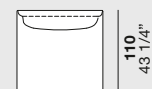
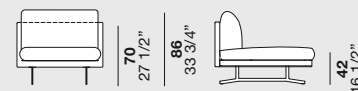

110  
43 1/4"

## Poltrone

Armchairs / Sillones / Fauteuil / Armlehnstühle / Кресла

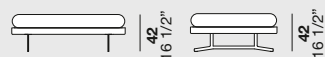

150  
59"

## Pouf

Pouf / Puffs / Pouf / Polsterhocker / Пуфы



110  
43 1/4"

**Divani con cuscini decorativi**

Sofas / Sofás / Canapés / Sofas / Диваны

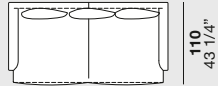

180 / 200 / 220 / 240 / 260  
70 3/4" 78 3/4" 86 1/2"  
94 1/2" 102 1/4"

**Divani per angolo sx o dx**

Left or Right facing sofas for corner / sofás para esquina izda. o dcha. / canapés pour coin gauche ou droit / Sofas für die li. oder re. Ecke / диваны для левого или правого угла

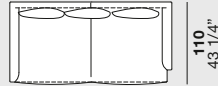

180 / 200 / 220 / 240 / 260  
70 3/4" 78 3/4" 86 1/2"  
94 1/2" 102 1/4"

**Moduli terminali sx o dx**

Left or Right facing end units / Módulos terminales izda. o dcha. / Modules terminaux gauches ou droits / Abschlusselemente li. oder re. / Терминальные лев. или прав. модули

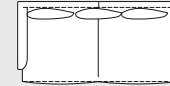

175 / 195 / 215 / 235 / 255  
69" 76 3/4" 84 3/4"  
92 1/2" 100 1/2"

**Chaise longue sx o dx**

Left or Right facing chaise longue / Chaise longue izda. o dcha. / Chaise longue gauche ou droite / Chaiselongue li. oder re. / Лев. или прав. шезлонги

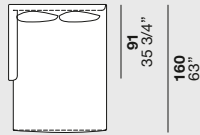
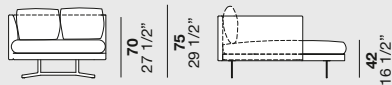

110  
43 1/4"

**Moduli penisola**

Peninsula units / Módulos península / Modules péninsule / Halbinsel-Module / Полуостровные модули

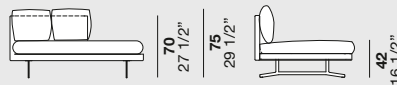

110  
43 1/4"

170  
67"

**Moduli centrali**

Central units / Módulos centrales / Modules centraux / Mittelelemente / Центральные модули

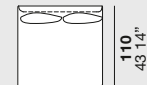

110  
43 1/4"



**Materiali e finiture**

Rivestimento:  
Tessuti / Pelle / Ecopelle  
Gambe in metallo:  
Verniciato Moka Shine /  
Verniciato Rame brunito  
-

**Materials and finishes**

Covering:  
Fabric / Leather / Ecoleather  
Metal legs:  
Moka Shine Painted /  
Rame brunito painted  
-

**Materiales y acabados**

Revestimiento:  
Tejidos / Piel / Eco-piel  
Patas de metal:  
Barnizado Moka Shine /  
Barnizado rame brunito  
-

**Matériaux et finitions**

Revêtement :  
Tissus / Cuir / Éco-cuir  
Pieds en métal :  
Verni Moka Shine /  
Verni rame brunito  
-

**Materialien und Ausführungen**

Bezug:  
Stoff / Leder / Kunstleder  
Beinen aus Metall:  
Lackiert Moka Shine / Brüniertes  
und lackiertes Kupfer  
-

**Материалы и варианты отделки**

Обивка:  
Ткань / Кожа / Экокожа  
Металлические ножки:  
Крашенный Moka Shine /  
Крашенный rame brunito

**Esempi di composizioni**

Composition examples / Ejemplos de composiciones / Exemples de compositions /  
Beispiele für Zusammenstellungen / Примеры композиций

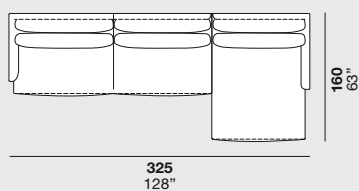
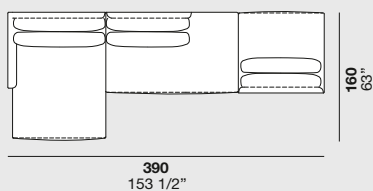
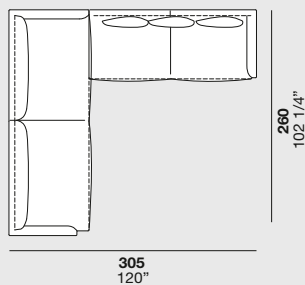
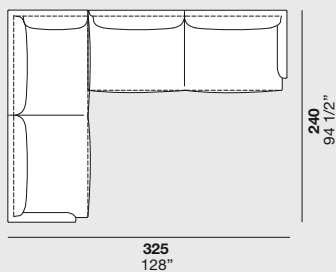

# Fyra

design R.D.A.



## Materiali e finiture

Gambe e piano:  
Fashion wood / Rovere laccati opachi.  
Staffe di collegamento in metallo:  
Verniciato Moka Shine

## Materials and finishes

Legs and top:  
Fashion Wood / Matt lacquered oak  
Metal brackets:  
Painted Moka Shine

## Materiales y acabados

Patas y sobre:  
Fashion wood / Roble lacados mate  
Soportes de unión de metal:  
Barnizado Moka Shine

## Matériaux et finitions

Pieds et plateau :  
Fashion wood / Chêne laqués mats  
Brides de raccordement en métal :  
Verni Moka Shine

## Materialien und Ausführungen

Beine und Platte:  
Fashion Wood / Eiche matt lackiert  
Verbindungswinkel aus Metall:  
Lackiert Moka Shine

## Материалы и варианты отделки

Ножки и столешница:  
Fashion wood / Дуб крашенный матовый  
Металлические соединительные кронштейны:  
Крашенный Moka Shine

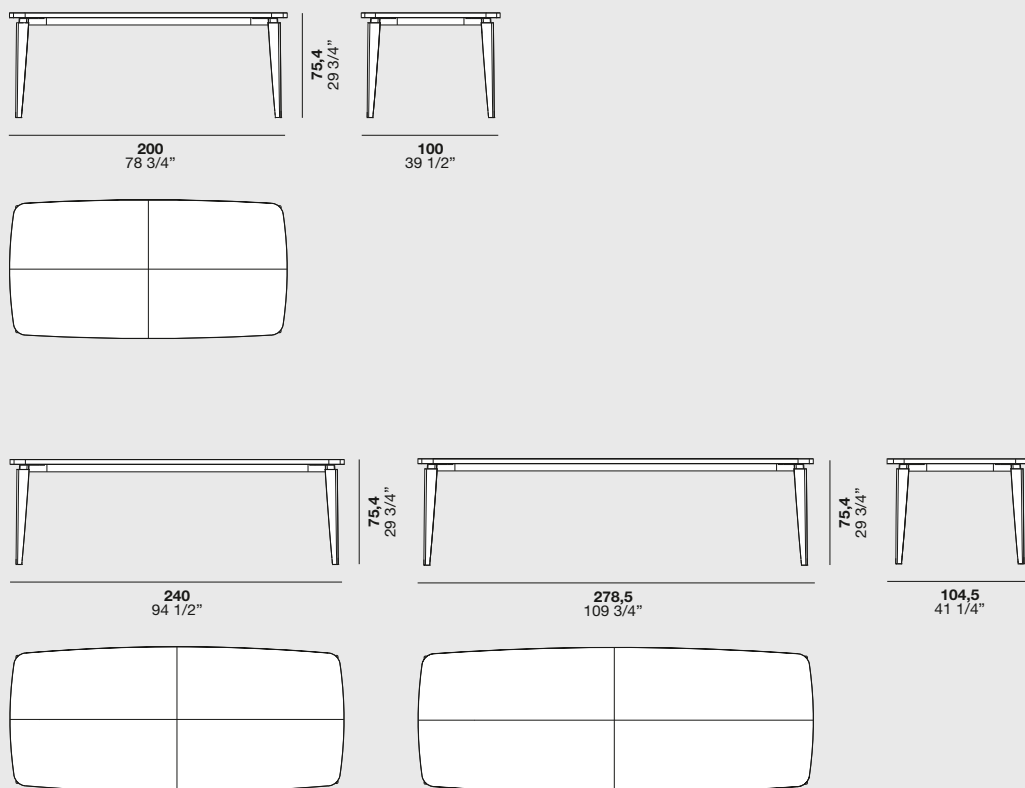

# Neyō

design Gordon Guillaumier

/technical data



## Materiali e finiture

Struttura metallo:  
Verniciato Moka Shine

Piano:

Fashion wood / Rovere laccati opachi /  
Marmo di Carrara

-

## Materials and finishes

Metal frame:  
Painted Moka Shine

Top:

Fashion Wood / Matt lacquered oak /  
Carrara marble

-

## Materiales y acabados

Estructura de metal:  
Barnizado Moka Shine

Sobre:

Fashion wood / Roble lacados mate /  
Mármol de Carrara

-

## Matériaux et finitions

Structure en métal :  
Verni Moka Shine

Plateau :

Fashion wood / Chêne laqués mats /  
Marbre de Carrara

-

## Materialien und Ausführungen

Metallkorpus:  
Lackiert Moka Shine

Platte:

Fashion Wood / Eiche matt lackiert /  
Carrara-Marmor

-

## Материалы и варианты отделки

Металлический каркас:  
Крашенный Moka Shine

Столешница:

Fashion wood / Дуб крашенный матовый  
/ Мрамор Carrara

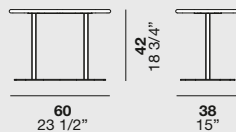

NEWS 2019

Alf DaFrè



# Neyō

design **Gordon Guillaumier**



## Materiali e finiture

Testiera e piattaforma:  
Tessuti / Pelle / Ecopelle  
Comodini: Fashion wood / Rovere  
laccati opachi / Marmo di Carrara  
Piedi: metallo verniciato Moka Shine

## Materials and finishes

Headboard and platform:  
Fabric / Leather / Ecological leather  
Bedside tables: Fashion Wood / Matt  
lacquered oak / Carrara marble  
Feet: Moka Shine painted metal

## Materiales y acabados

Cabecera y plataforma:  
Tejidos / Piel / Eco-piel  
Mesitas de noche: Fashion wood /  
Roble lacados mate / Mármol de Carrara  
Patas: metal barnizado Moka Shine

## Matériaux et finitions

Tête de lit et encadrement :  
Tissus / Cuir / Éco-cuir  
Chevets : Fashion wood / Chêne laqués  
mats / Marbre de Carrara  
Pieds : métal verni Moka Shine

## Materialien und Ausführungen

Kopfteil und Liegefläche:  
Stoff / Leder / Kunstleder  
Nachtische: Fashion Wood / Eiche matt  
lackiert / Carrara-Marmor  
FüÙe: Metall lackiert Moka Shine

## Материалы и варианты отделки

Головная спинка и платформа:  
Ткань / Кожа / Экокожа  
Тумбочки: Fashion wood / Дуб  
крашеный матовый / Мрамор Carrara  
Ножки: крашеный металл Moka Shine

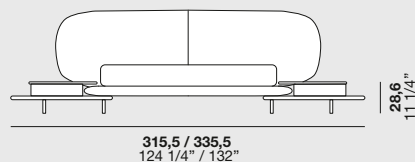
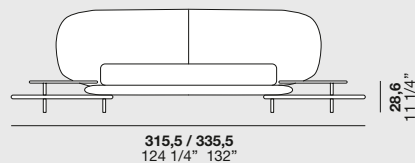
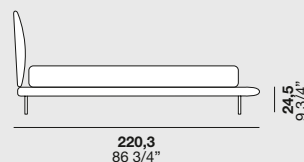
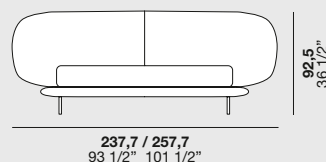

# Jetty

design **Gordon Guillaumier**



## Materiali e finiture

Struttura metallo:  
finitura "elettrocol"  
Testiera:  
Tessuti / Pelle / Ecopelle

-

## Materials and finishes

Metal frame:  
Elettrocol finish  
Headboard:  
Fabric / Leather / Ecological leather

-

## Materiales y acabados

Estructura de metal:  
acabado "elettrocol"  
Cabecera:  
Tejidos / Piel / Eco-piel

-

## Matériaux et finitions

Structure en métal :  
finition « elettrocol »  
Tête de lit :  
Tissus / Cuir / Éco-cuir

-

## Materialien und Ausführungen

Metallkorpus:  
Ausführung „Elettrocol“  
Kopfteil:  
Stoff / Leder / Kunstleder

-

## Материалы и варианты отделки

Металлический каркас:  
отделка "elettrocol"  
Головная спинка:  
Ткань / Кожа / Экокожа

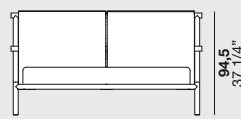

174  
68 1/2"



212,2  
83 1/2"

# Relief

Collezioni tappeti / Rugs collection

---

**Materiale: Viscosa.**

**Struttura: Tessuta a mano su telai artigianali.**

Material: Viscose.

Frame: Woven by hand on a loom.



Sabbia



Terra



Pietra

art direction  
**Bruna Vaccher**  
**Genny Canton**

graphic  
**Genny Canton Studio**

photo  
**Paolo Contratti**

styling  
**Rosanna Bignucolo**  
**Claudia Barberi**

separations  
**Luce srl**

print  
**OGM**

thanks to  
**Être Concept Store**  
**Pordenone**



Verifica le finiture disponibili sul nostro sito internet. / Check the finishes available on our website. / Consulte los acabados disponibles en nuestro sitio web. / Vérifiez les finitions disponibles sur notre site internet. / Überprüfen Sie auf unserer Webseite, ob die gewünschte Ausführung erhältlich ist. / Познакомьтесь с вариантами отделки на нашем интернет-сайте [www.alfdafre.it](http://www.alfdafre.it)

**ALF UNO s.p.a.** si riserva di apportare in qualsiasi momento modifiche a prodotti, misure e materiali, che ritenesse utili per esigenze di carattere produttivo e commerciale. Per essere sempre aggiornati vi invitiamo a consultare il nostro sito internet [www.alfdafre.it](http://www.alfdafre.it).

#### **LE FINITURE**

I materiali utilizzati dalla nostra azienda sono selezionati tra i più affidabili per applicazione e resa estetica. Nonostante questo devono considerarsi tollerabili alcune differenze dovute alle caratteristiche stesse di materiali come essenze naturali, vetri, laccature e all'artigianalità di alcune fasi del processo produttivo che da sempre è un nostro valore aggiunto. Inoltre alcune finiture possono subire nel tempo maturazioni dovute all'azione della luce e del tempo. È importante quindi specificare se nell'ordine vi sono sostituzioni o completamenti per valutare insieme il miglior modo di procedere. Le tonalità di colore e le finiture illustrate vanno considerate puramente indicative. Verificare sempre la fattibilità dell'abbinamento finiture consultando l'interno del listino.

**ALF UNO s.p.a.** reserves the right to make any changes to products, measurements and materials at any time deemed useful for manufacturing and sales purposes. To stay up to date at all times, please visit our website [www.alfdafre.it](http://www.alfdafre.it)

#### **FINISHES**

The materials we use are selected among the most reliable products in terms of application and aesthetic rendering. Despite this, certain differences due to the very characteristics of materials such as natural wood finishes, glass and lacquers must be considered tolerable, as well as the hand-crafted nature of certain phases of the production process, which has always been one of our added values. In addition, some finishes may change over time, due to the effects of light and time. It is therefore important to specify whether there are replacements or completions in the order to assess the best way to proceed together. The finishes featured in this sample collection are purely indicative and are not available for all products. Please check in the price list if the finish is available for the chosen item. Orders will not be accepted for products with finishes not included in the price list. The colour shades and finishes illustrated herein are to be considered purely indicative. Always check the feasibility of finish combinations by consulting the price list contents.

# world wide offices

**CANADA & USA NORTH-EAST COAST**  
TEL. (416) 663-2223 - FAX (416) 663-2594  
E-MAIL: alf@rosnerinternational.com

**CENTRAL AMERICA - CARIBBEAN ISLANDS**  
TEL. (787) 786-9705 - FAX (787) 785-9835  
E-MAIL: alvin@arodz.net

**LOUISIANA - OKLAHOMA - TEXAS**  
TEL. (405) 204-4737  
E-MAIL: parke@furniture sourcetexas.com

**ARIZONA - OREGON - WASHINGTON - NORTHERN CALIFORNIA - ALASKA - COLORADO - UTAH - NEW MEXICO - HAWAII**  
TEL. (707) 291 2995  
E-MAIL: corneliusen@aol.com

**FLORIDA - ALABAMA**  
TEL. (321) 773-6982 - FAX (321) 773-8324  
E-MAIL: lloydavisiii@aol.com

**MID-WEST/SOUTH-EAST (EXCLUDING FLORIDA)**  
TEL. (310) 636-1199 - FAX (310) 636-4433  
E-MAIL: bill@weisbergsales.com

**U.S.A.: HIGH POINT SHOWROOM (OPEN ONLY DURING FURNITURE MARKET DATES)**  
TEL. (336) 889-9027

**NEVADA-SOUTHERN CALIFORNIA**  
E-MAIL: alf@alf.it

**AUSTRALIA & NEW ZEALAND**  
TEL. (08) 9314 3999 - FAX (08) 9314 3777  
E-MAIL: ross@merlino.com.au

**MEXICO**  
TEL. (55) 5351-1348  
E-MAIL: furniturezenteno@yahoo.com

**AUSTRIA**  
TEL. +43(0)4240 20358 - FAX +43(0)4240 20370  
E-MAIL: luca.zoldan@designphilosophy.org

**GERMANY**  
TEL. +49 89 60667983  
E-MAIL: sonogo@gmx.de

**SWITZERLAND**  
E-MAIL: alf@alf.it

**DENMARK**  
TEL. +45 20475875  
E-MAIL: lehri@mail.dk

**BELGIUM - LUXEMBOURG**  
TEL. +32 471726845  
E-MAIL: jan@idsa.be

**HOLLAND**  
TEL. 0031 344 60 90 80 - FAX 0031 344 60 90 89  
E-MAIL: info@hadu.nl

**EAST EUROPE**  
TEL. +39 3484064921  
E-MAIL: caputomauro@libero.it

**ICELAND**  
TEL. +354 5880640  
E-MAIL: casa@casa.is

**U.K. - IRELAND**  
TEL. + 44 7980019194  
E-MAIL: design@atmosphere1102.com

**FRANCE - BRETAGNE - NORMANDIE - CENTRE**  
TEL. 0033608423974  
E-MAIL: contact@jmcsarl.fr

**FRANCE - EST**  
TEL. 0033615436985  
E-MAIL: ch.vidrin@wanadoo.fr

**FRANCE - SUD-EST**  
TEL. 06 33 83 87 58  
E-MAIL: fd.developpement@orange.fr

**FRANCE - ILE DE FRANCE - NORD**  
TEL. 06 60 65 61 62  
E-MAIL: decaix.christophe@wanadoo.fr

**FRANCE - SUD-OUEST**  
TEL. 06 40 55 21 88  
E-MAIL: tgrird.gt@gmail.com

**FRANCE - RHONE/ALPES**  
TEL. 0033689923725 - FAX 0033466777294  
E-MAIL: fredericc.ac@orange.fr

**HELLAS - CYPRUS**  
TEL. +39 0434 77199 - FAX +39 0434 779591  
E-MAIL: luca.zoldan@designphilosophy.org

**INDIA - SRI LANKA**  
TEL. +91 8041285290 - 91 9845636644  
E-MAIL: keith@kreb.in

**ALF GROUP MIDDLE-EAST REP. OFFICE**  
TEL. +961 4718160 - FAX +961 4718159  
E-MAIL: info@alfme.com

**POLAND**  
TEL. +48 618175994 - FAX +48 616429218  
E-MAIL: karina@qualitaitaliana.pl

**CSI E PAESI BALTICI**  
TEL. +7-812-3322934 - FAX +7-812-3322934  
E-MAIL: office.spb@alf.it

**ALGERIA - TUNISIA**  
E-MAIL: waliitaliandesign.it

**SOUTH AFRICA**  
TEL. +27 0861777123 - FAX +27 0118262186  
E-MAIL: les@alfsa.co.za

**SPAIN - ANDALUCIA Y EXTREMADURA**  
TEL. +34 958818744 - FAX +34 958302251  
E-MAIL: info@javiercastellon.com

**SPAIN - CASTILLA Y LEON**  
TEL. +34983541003 - FAX +34983541003  
E-MAIL: evaristorg@gmail.com

**SPAIN - BARCELONA - CATALUNYA Y ANDORRA**  
TEL. +34 935531590 - FAX +34 935531590  
E-MAIL: albert-miro-mauri@hotmail.com

**SPAIN - VALENCIA, MURCIA Y CASTILLA LA MANCHA**  
TEL. +34 607 210 185  
E-MAIL: jlhervas.vic@gmail.com

**SPAIN - MADRID**  
TEL. +34 607 363 016 - FAX +34 91 351 57 27  
E-MAIL: e.sesenna@telefonica.net

**SPAIN - SORIA, LA RIOJA, MALLORCA, MENORCA, IBIZA, FORMENTERA Y ASTURIAS**  
E-MAIL: alf@alf.it

**SPAIN - ARAGÓN**  
TEL. +34 650236594 - FAX +34 976598600  
E-MAIL: davidmirandamoreno@gmail.com

**SPAIN - PAIS VASCO, LA RIOJA, NAVARRA Y CANTABRIA**  
TEL. +34 656 703 204  
E-MAIL: iruoffice@iruoffice.com

**TURKEY**  
E-MAIL: alf@alf.it

**INDONESIA - SINGAPORE**  
TEL. +65 91214415  
E-MAIL: alberto.fantin@soluzioni.com.sg

## Alf DaFre®

ALF UNO Spa  
Via S. Pio X 17  
31018 Francenigo di Gaiarine  
Treviso, Italy  
Tel. +39 0438 997111  
Fax Italia +39 0438 997245  
Fax estero +39 0438 997246  
www.alfdafre.it alf@alf.it



ALF UNO Spa  
è certificata **ISO 9001:2008**  
ALF UNO Spa  
is certified by the **ISO 9001:2008**